



LES CONSTRUCTEURS  
ET AMÉNAGEURS



FFB



# La Préfabrication et la Maison connectée

David Gomes  
RÉABELLE

Luc Monnet  
ETC





# 1 Présentation de l'Entreprise

1991 : Construction de l'Artoire

2000 : Maisons RVE

2014 : Maisons RéaBelle  
(Promotion & CCMI)



# Vue d'ensemble du projet



# Vue d'ensemble du projet



LES CONSTRUCTEURS  
ET AMÉNAGEURS





LES CONSTRUCTEURS  
ET AMÉNAGEURS



# Méthode traditionnelle soubassement



# Méthode Préfabrication soubassement





LES CONSTRUCTEURS  
ET AMÉNAGEURS



FFB

**KP1**  
Créateur de systèmes constructifs



**RéaBelle**  
PROMOTION



LES CONSTRUCTEURS  
ET AMÉNAGEURS



# Méthode traditionnelle élévation



# Méthode préfabrication élévation





LES CONSTRUCTEURS  
ET AMÉNAGEURS



bouyer leroux



## Processus actuel pour 1 maison

↑ Coulage des fondations

Fin du Gros Œuvre ↑

20 jours à 2 personnes

## Processus Préfabrication

6 jours à 2 personnes

## PROJET DE BASE



Conforme  
énergie 2



Conforme  
carbone 1  
Hors aménagement  
parcelle



## PROJET PREFABRICATION



Conforme  
énergie 2



Conforme  
carbone 1  
Hors aménagement  
parcelle

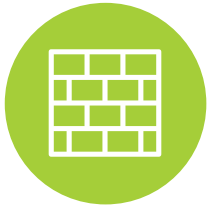

157  
KgCO<sub>2</sub>/m<sup>2</sup>.an  
pour une  
maison

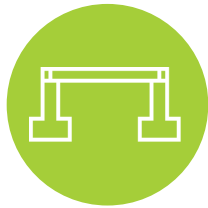

25 %  
Du PCE totale  
d'une maison



- 24 %  
de CO<sub>2</sub> sur les lots  
fondation/infrastructure  
et maçonnerie

# Présentation du dossieret pour PAC Air/Eau

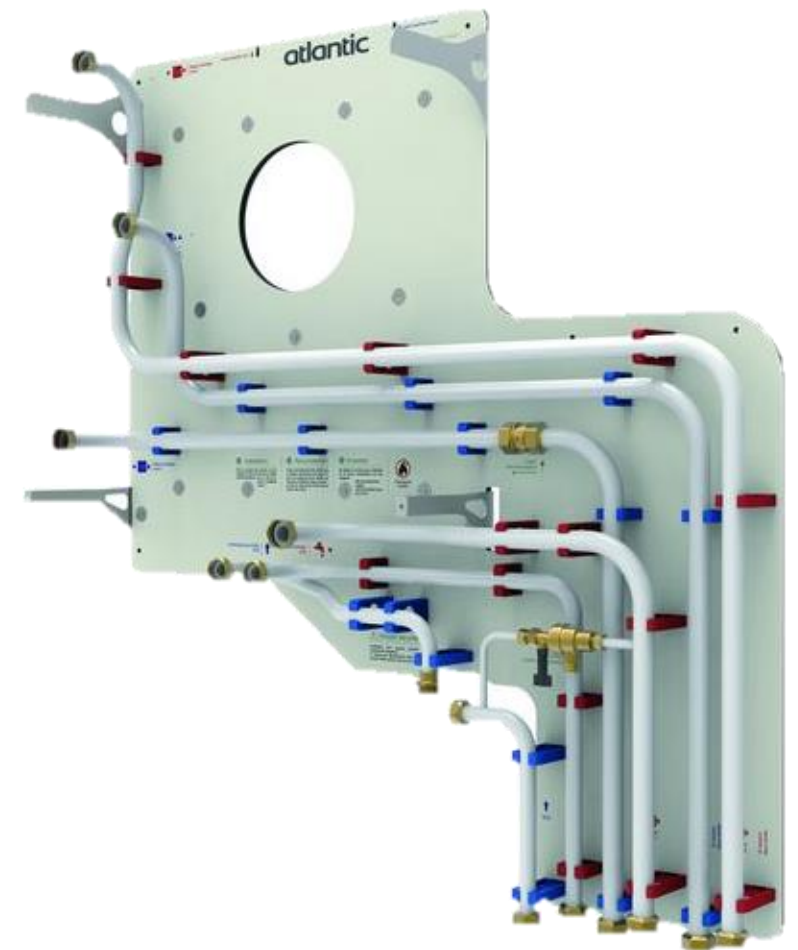



LES CONSTRUCTEURS  
ET AMÉNAGEURS



FFB

# Maison connectable

**DELTA  
DORE**  
Smart is the new power



**RéaBelle**  
PROMOTION

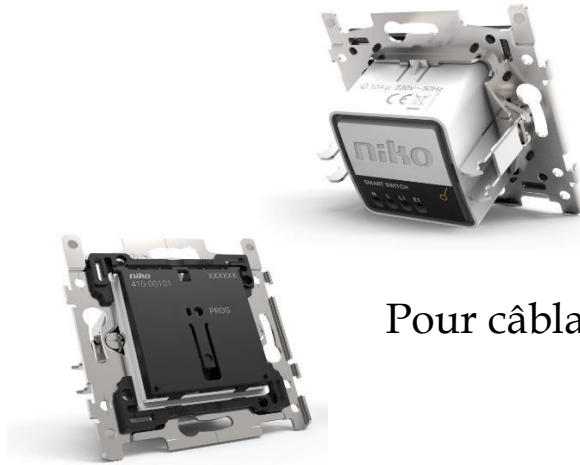

Pour câblage traditionnel



Extensions sans fil



Double interrupteur sans fil

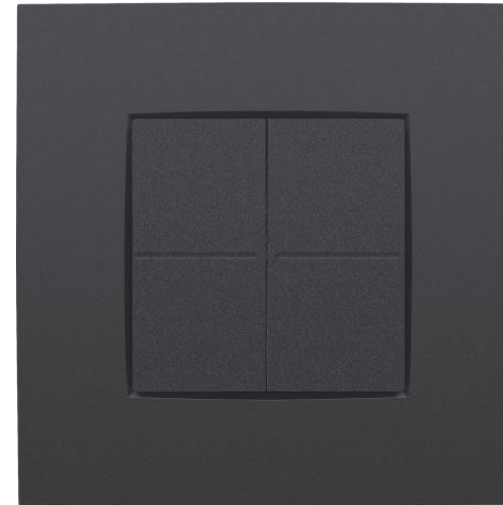

Interrupteur quadruple sans fil

# Bilan du projet



7 jours gagnés  
pluie  
électrique et  
fluide  
par logement

Gros œuvre :  
0 palette  
consignée

Gros œuvre :  
-14 jours  
travaillés  
par maison

- 1/2 journée de  
plomberie par  
pavillon

- 5 bennes à  
gravats sur le  
chantier

**3 mois de  
gagnés sur  
l'opération**





LES CONSTRUCTEURS  
ET AMÉNAGEURS



3<sup>ème</sup> journée  
**PROMOTEURS  
PARTENAIRES  
LCA-FFB**

